



Technical Specification Sheet

# CladKing

A dual circuit vacuum cladding lifter specifically developed for the safe, quick, handling and installation of composite wall and roof panels. The CladKing features a dampened hydraulic tilt mechanism allowing panels to be safely tilted from horizontal to vertical.

Multi-positional pads and an extendable frame add to the lifter's versatility making it suitable for all panel types - PUR, mineral wool and EPS - and most surface finishes. Aluminium multi-configuration frame offers minimal load deflection.

## Technical Specifications

<b>Typical application</b>	Installation of sandwich panels in industrial, commercial and cold store construction
<b>The building panels to be processed</b>	<ul style="list-style-type: none"> <li>- gastight, other materials possible but subject to test</li> <li>- must be smooth or slightly structural</li> <li>- composite panels (PUR, EPS, mineral wool), glass, sheet metals and plastics</li> </ul>
<b>Safe working load</b>	320kg
<b>Weight of device</b>	118kg (136kg with extensions arms)
<b>Control options</b>	Optional cable or remote
<b>Power supply</b>	Pump: 12v DC from rechargeable battery Battery Charger: 110v/240v 20/60Hz single phase factory selectable
<b>Vacuum production</b>	1 pump, 2 vacuum tanks
<b>Vacuum pads</b>	Black rubber with closed cell foam seal (457x203mm)
<b>Standard accessories</b>	4 x extension arms, reverse air flow (blow-off), dampened tilting
<b>Optional accessories</b>	<ul style="list-style-type: none"> <li>- Cable remote control</li> <li>- Radio remote control</li> <li>- Replaceable foam pad seals</li> <li>- Adjustable lifting ball</li> </ul>



## Dimensions (all measurements are in mm)

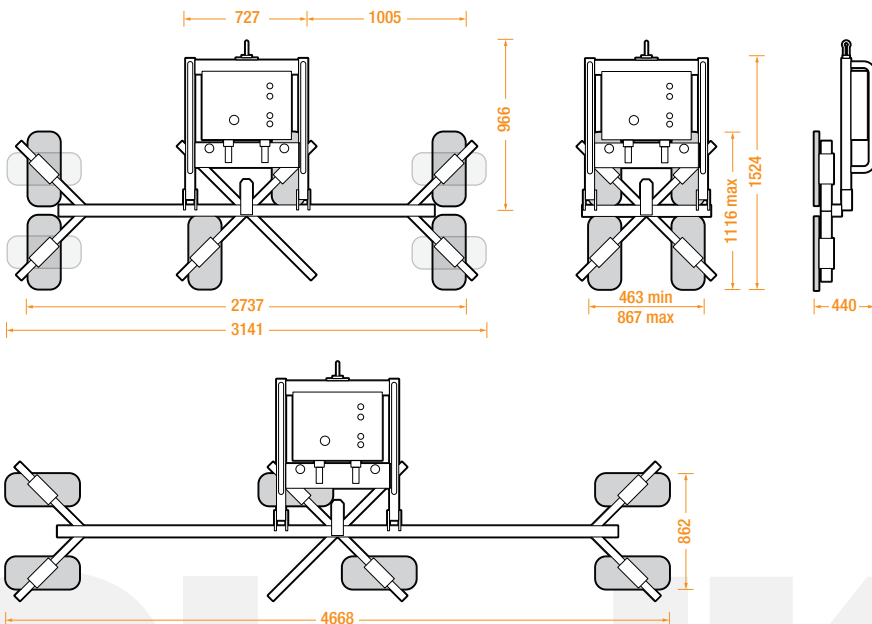

**HIRE OR PURCHASE TODAY - CALL OUR SPECIALIST TEAM ON:**

North: +44 (0)161 683 2580 - South: +44 (0)1844 202 071 - Scotland: +44 (0)1698 824444

[www.ggrcladding.com](http://www.ggrcladding.com)