



Technical Specification Sheet

# Stone Cladding Lifter

New to GGR Hire, the Stone Magnet comes with a unique 360° continuous rotation and 90° tilt for precise manoeuvring of stone, paving and concrete slabs.

Perfect for stone cladding installation, masonry installation, commercial stone veneers and heavy duty lifting on construction sites, the Rotating Stone Magnet features constant running vacuum technology with a load capacity of up to 300kg.

Designed as a below-the-hook lifter, the rotating stone magnet allows quick, easy and precise lifting of stone panels, paving and cladding. This vacuum lifter is a popular choice with stone masons, natural stone manufacturers, stone merchants and fabrication yards, landscape architects and more.

Manual tilting from vertical or horizontal positions, along with lockable 360° rotation, ensure safe and efficient handling of stone into the required position.

**Dimensions** (all measurements are in mm)

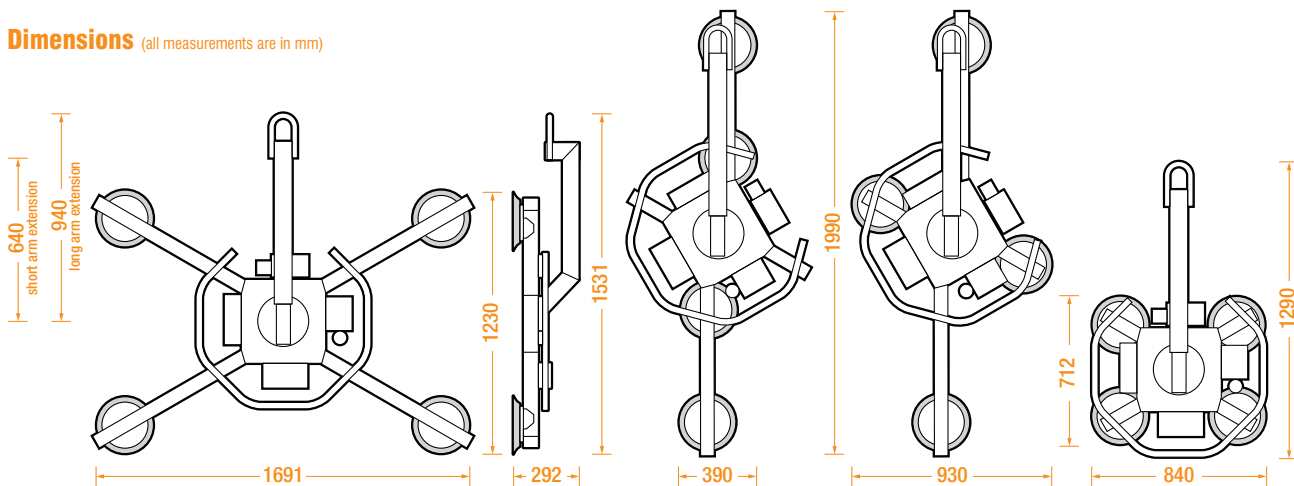

**HIRE OR PURCHASE TODAY - CALL OUR SPECIALIST TEAM ON:**

North: +44 (0)161 683 2580 - South: +44 (0)1844 202 071 - Scotland: +44 (0)1698 824444