



Technical Specification Sheet

Forklift Verti-Clad

The new Forklift Verti-Clad is the ideal aid for lifting and installing vertical wall panels including composite and coldstore materials up to 15m long.

Designed to attach to a forklift or telehandler, the Forklift Verti-Clad effortlessly lifts heavy panels from a stack and rotates them into an upright position ready for installation thanks to its 180° rotation and 90° slew left and right.

Part of the Wirth OKTOPUS® range, the Forklift Verti-Clad comes with a 400kg capacity and can install up to 6 panels per hour, helping to improve installation time on site and reduce the risk of injury or damage from manual handling.

The Forklift Verti-Clad is compatible with different wall and cold store panel brands including Kingspan insulated wall systems, Isoclad cold store PIR panels, Eurobond rockwool panels, Trimo façade systems and more. Contact our lifting advice team today to find out more.

Dimensions (all measurements are in mm)

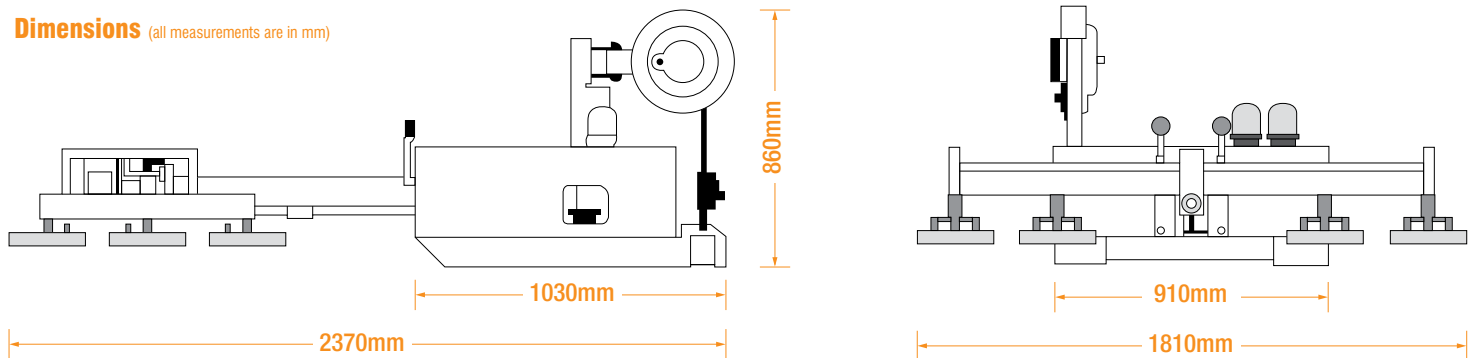

HIRE OR PURCHASE TODAY - CALL OUR SPECIALIST TEAM ON:

North: +44 (0)161 683 2580 - South: +44 (0)1844 202 071 - Scotland: +44 (0)1698 824444